

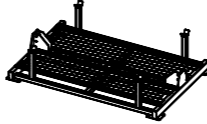

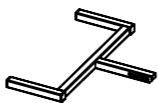



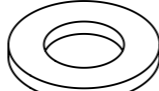

SPARE PARTS GUIDE

ITEM NO.	SPARE PART DESCRIPTION	PART #	REFERENCE IMAGE
1	MOBILE MATERIAL RACK CHASSIS 1560W X 1000D X 358H	CH1	
2	BUNDLERACK BR-EA END ARM	BR-EA	
3	BOLT - M12 X 80 HEX HEAD SET SCREW, BZP STEEL (HIGH TENSILE GRADE 8.8)	BLT-M12X80-H	
4	WASHER - FLAT M12, BZP STEEL	WAS-M12-F	
5	NUT - M12 NYLOC, GRADE 8, BZP STEEL	NUT-M12-NN	
6	CASTOR SET-160MM RED HD WHEELS: 2X SWIVEL BRAKED, 2X SWIVEL; 16X M10X20 BOLTS, 16X M10 NYLOCS	CASHD3	
6.1	CASTOR - 160mm RED HD RUBBER ON NYLON, SWIVEL BRAKED, 350KG CAPACITY	CAS160HD-SS-SB	
6.2	CASTOR - 160mm RED HD RUBBER ON NYLON, SWIVEL, 350KG CAPACITY	CAS160HD-SS-SW	
6.3	FIXING KIT – COMES WITH 16X M10X20 HEX HEAD SCREWS, 16X M10 NYLOCS	M10-KIT2	
7	1500KG AUTO-RETRACTABLE RATCHET STRAP 3m X 50mm WITH FIXING KIT	RTCH-STP3-50-K	

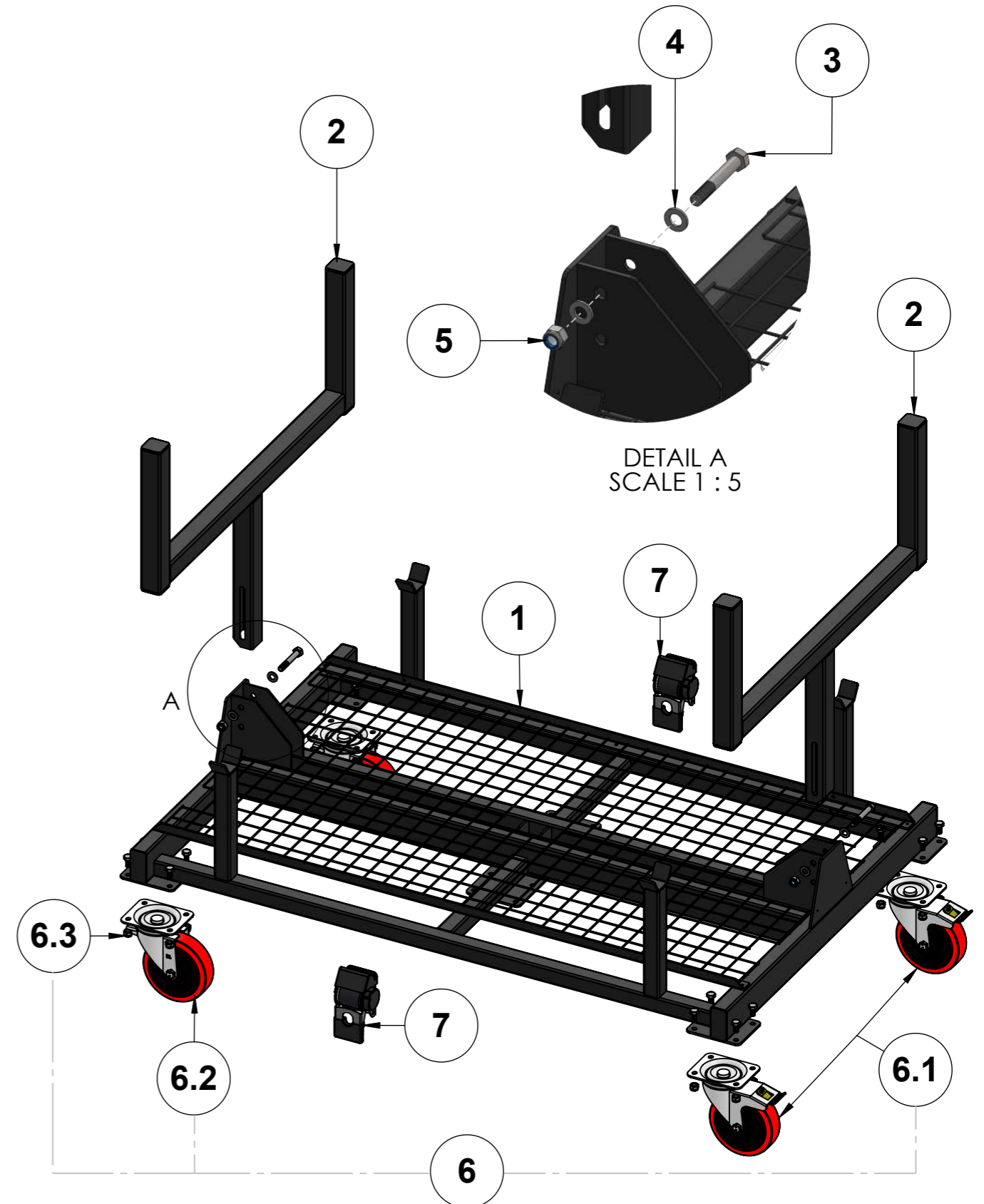

PRODUCT NAME:
BUNDLERACK BR1

PRODUCT VERSION:
P01

WEIGHT:
90kg

NOTES:

LAST DATE SAVED:

13/08/2024

THIS DRAWING MAY NOT BE COPIED, PUBLISHED OR TRANSMITTED TO A THIRD PARTY WITHOUT THE PRIOR WRITTEN CONSENT OF ARMORGARD LIMITED.

SPARE PARTS GUIDE

PRODUCT COLOUR:
RAL7021 DARK GREY

LEAD TIMES MAY VARY – PLEASE ENQUIRE

PAGE 1 of 1