

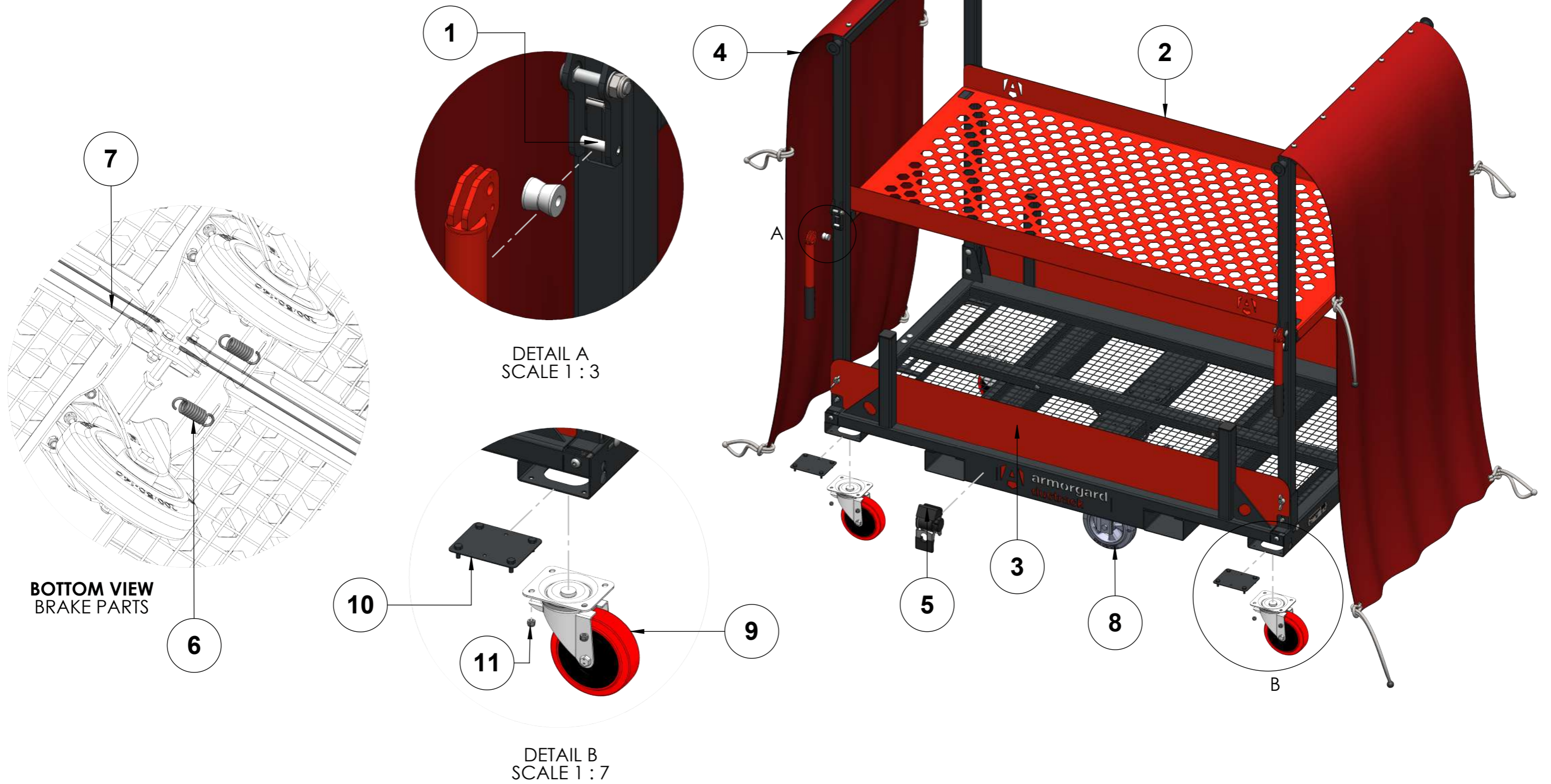





SPARE PARTS GUIDE

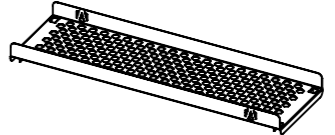
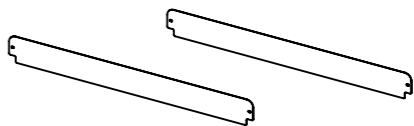
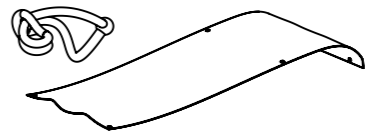

	PRODUCT NAME: DUCTRACK - DR2	PRODUCT VERSION: T01	NOTES:	LAST DATE SAVED: 09/01/2025
		WEIGHT: 185KG		
THIS DRAWING MAY NOT BE COPIED, PUBLISHED OR TRANSMITTED TO A THIRD PARTY WITHOUT THE PRIOR WRITTEN CONSENT OF ARMORGARD LIMITED.	SPARE PARTS GUIDE	PRODUCT COLOUR: RAL7021 DARK GREY		PAGE 1 of 2
LEAD TIMES MAY VARY – PLEASE ENQUIRE				

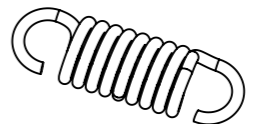
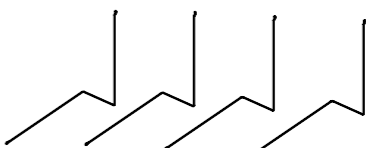
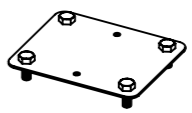
ITEM NO.	DESCRIPTION	PART #	REFERENCE IMAGE
1	ROLL PIN - 5MM DIAMETER, 16MM LENGTH	PIN-RP-5X16	
2	DUCTRACK DR2-S SHELF FOR DR2	DR2-S	
3	DUCTRACK DR-SK SIDE KIT, PAIR	DR-SK	
4	CURTAIN - ARMORGARD BRANDED PRINTED PVC WITH BUNGEE CORDS, 1100W X 2060H	CUR-PR-1100	
5	1500KG AUTO-RETRACTABLE RATCHET STRAP 3m X 50mm WITH FIXING KIT	RTCH-STP3-50-K	
6	EXTENSION SPRING - ZINC COATED, 19MM RATE 27.9N MM L57MM (LE125G02)	SPRG-1957	
7	STEEL CABLE - WIRE FOR DUCTRACK BRAKE, WITH FERRULES AND THIMBLES, 3MM DIAMETER 2185MM LENGTH	STL-WRE-2185	
8	200mm CASTOR DEAD-MAN BRAKED BLACK RUBBER ON ALUMINIUM - CAPACITY 500KG	CAS200-SS-DB	
9	CASTOR - 160mm RED HD RUBBER ON NYLON, SWIVEL, 350KG CAPACITY	CAS160HD-SS-SW	
10	CASTER FIXING PLATE (105MMX80MM HOLE CENTRES)	CAS-CP	
11	FIXING KIT - COMES WITH 16X M8 NYLOCS	M8-NUT-KIT	