

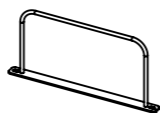

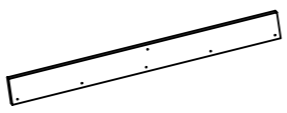

# SPARE PARTS GUIDE

ITEM NO.	DESCRIPTION	PART #	REFERENCE IMAGE
1	LOADALL LA1500-HDL D-HANDLE	LA1500-HDL	
2	LOADALL LA1500-BRD BASE WOOD BOARD, 1500W X 150D X 25H	LA1500-BRD	
3	LOADALL LA1500-SLT 'A' FRAME WOOD SLAT, 1500W X 87D X 18H	LA1500-SLT	
4	LOADALL LA1500-C TOP CLAMP AND WING NUT KIT, COMES WITH 2X WING CLAMP BRACKETS, 1X WING NUT	LA1500-C	
5	CASTOR SET - 200mm BLACK WHEELS: 2X SWIVEL BRAKED, 2X SWIVEL; 16X M10X70 BOLTS, 16X M10 NYLOCS	CASS5	
5.1	CASTOR - 200mm BLACK RUBBER ON ALUMINIUM, SWIVEL BRAKED, 500KG CAPACITY	CAS200-SS-SB	
5.2	CASTOR - 200mm BLACK RUBBER ON ALUMINIUM, SWIVEL, 500KG CAPACITY	CAS200-SS-SW	
6	1500KG AUTO-RETRACTABLE RATCHET STRAP 3m X 50mm WITH FIXING KIT	RTCH-STP3-50-K	

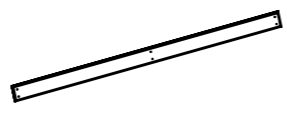
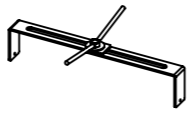
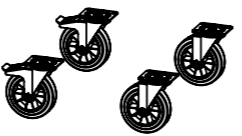

PRODUCT NAME:  
**LOADALL LA1500**

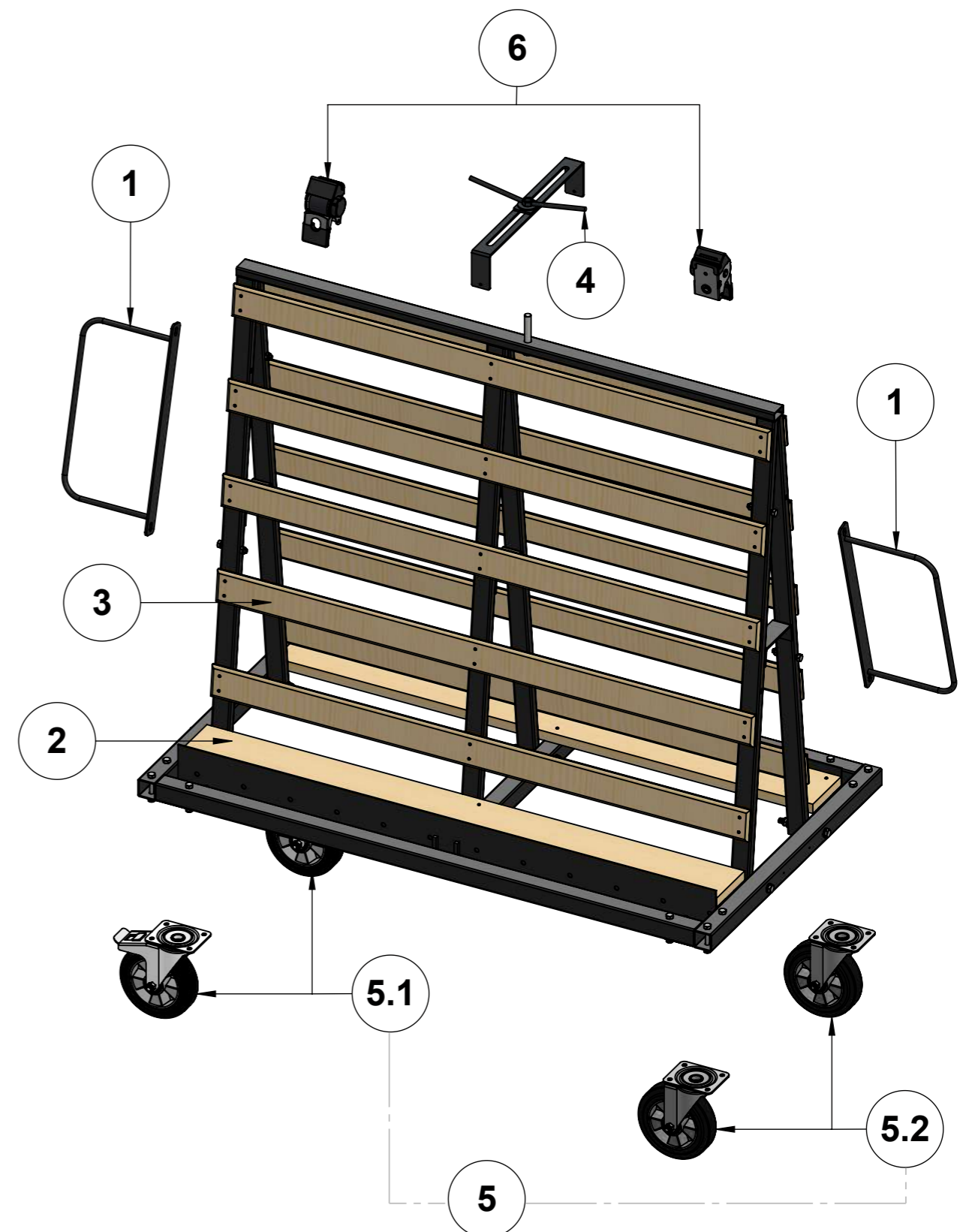
PRODUCT VERSION:  
P01

WEIGHT:  
105KG

NOTES:

LAST DATE SAVED:

14/08/2024

THIS DRAWING MAY NOT BE COPIED, PUBLISHED OR TRANSMITTED TO A THIRD PARTY WITHOUT THE PRIOR WRITTEN CONSENT OF ARMORGARD LIMITED.

SPARE PARTS GUIDE

PRODUCT COLOUR:  
RAL7021 DARK GREY

LEAD TIMES MAY VARY – PLEASE ENQUIRE

**PAGE 1 of 1**