



fittingstor™

Product code: FC3

- » Secure cabinet designed for storing fittings and materials.
- » Comes with three removable shelves and 15 storage bins (code FCB).
- » Heavy-duty doors with anti-jemmy protection.



Product features



2x 5-lever deadlocks



Forklift skids



Suitable for site

Specifications

Weight	120kg
Colour	Black grey: RAL 7021
Suitable for	Site
Finished coating	Powder coated
Material & thickness	1.5mm and 2mm steel
Quantity of keys	3 keys
Suitable for vehicle mounting	No
How are castors fitted?	Quick-fix bolt on castor kit
Other sizes available	4 other sizes
Qty of shelves as standard	3 shelves

Dimensions - External dimensions includes protrusions

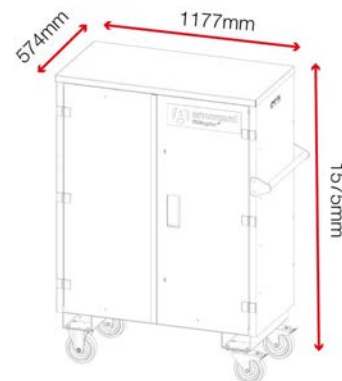

Optional extras - Contact Armorgard to find out more



Fittings bins FCB

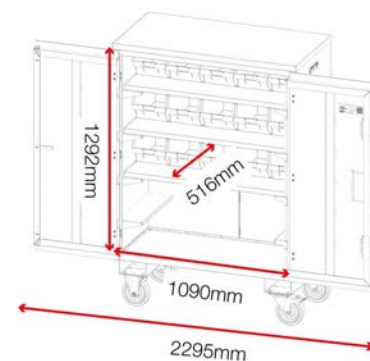

Disclaimer: all dimensions and weights are approximate