



mobile tuffbench™

with vices fitted

Product code: MBH12-VF

- » Ideal workbench for many applications.
- » Fitted with chain vice & engineers vice, making it ideal for M&E.
- » Integral secure cabinet to lock away tools and equipment.



Watch the Mobile
TuffBench in
action



Product features



2x 5-lever
deadlocks



Extra-heavy duty
160mm castors



Four way forklift
skids



No detachable
parts



Suitable for site



Weight load limit

Specifications

Weight	125kg
Colour	Black grey: RAL 7021
Finished coating	Powder coated
Material & thickness	2mm and 3mm steel
Quantity of keys	3 keys
Does it have storage	Yes
How are castors fitted?	Quick-fix bolt on heavy-duty castor kit

Dimensions - External dimensions includes protrusions

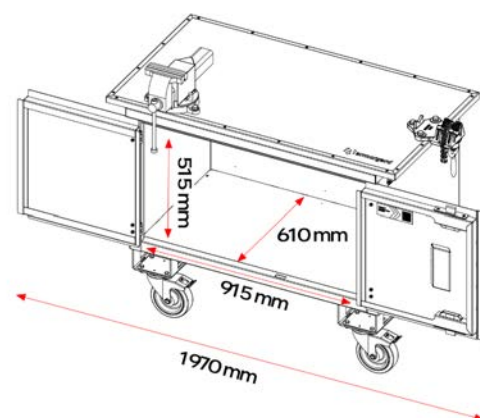
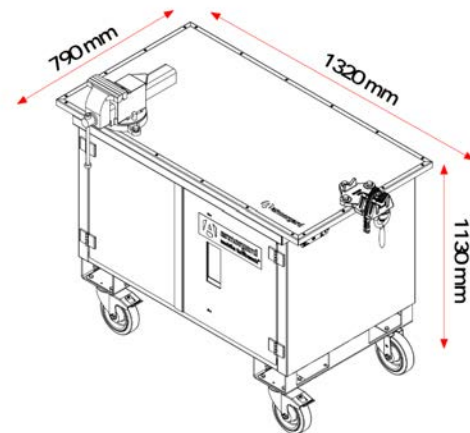

Related products - Contact Armorgard to find out more



TuffBench BH10-HWWF



TuffBank TB2



Mobile TuffBench MBH12

Disclaimer: all dimensions and weights are approximate