



Barcode: 5060452083131

Patent: GB2301393

Version: v101.4

# volthub™

## Safe Li-Ion battery charging

Product code: VH16-240

- » Designed to safely charge and store Li-Ion batteries.
- » Passive and active technology with battery backup.
- » Weatherproof, IP55 rated, secure and mobile, VoltHub can go anywhere.

### Product features



240V 32A IP67 power inlet



Standard 200mm castors



Automatic fire suppression



Crane lifting eyes



Power supply 240V



RCD Protected



Safety signage



Suitable for site

### Specifications

Weight	334kg
Colour	Black grey: RAL 7021, Traffic red: RAL 3020
Suitable for	Li-Ion battery charging
Finished coating	Powder coated
Material & thickness	1.5mm steel
Quantity of keys	2 keys
How are castors fitted?	Castor plates
Ventilation	Yes
Qty of shelves as standard	16 lockers (padlockable)
Qty of power sockets	32x 240V sockets

### Dimensions - External dimensions includes protrusions

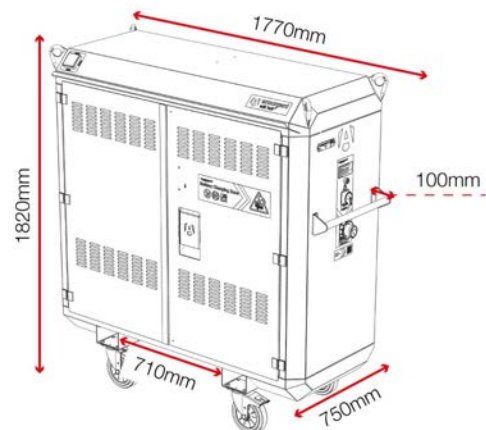

### Related products - Contact Armorgard to find out more



PowerStor PWR1



PowerStor PWR2



VoltHub VH16-110

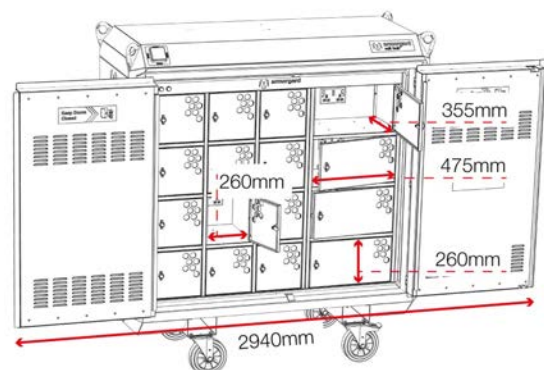

Disclaimer: all dimensions and weights are approximate

# fire suppression systems



## Armorgard VoltHub

The VoltHub is a unique solution to safely charging Lithium-Ion batteries. Designed with an integrated fire safety system that auto-activates in an emergency, it uses a special fire suppressant designed and tested with Lithium-Ion battery fires.



## Information



## Certification

NTA8133-2021

EN60529: 1992 + A2: 2013

NEN 1568

BS EN IEC 61000-6-3:2021

BS EN IEC 61000-6-2:2019

EN 60335-1:2012

EN 60335-2-29: 2019

EN 3-7+A1:2007 & NF074

Warning and information signage is displayed visibly to encourage safe usage.  
Completely free from the prohibited PFAS.

The VoltHub uses a pressurised targeting system that will detect and deploy the suppressant directly to the source of a thermal runaway event. The cooling properties of the suppressant released act fast as a catalyst to thermal runaway, providing containment and isolation of the battery fire. This rapid containment prevents thermal propagation of a faulty battery pack from affecting adjacent batteries.

The reason normal fire extinguishers are ineffective with LIB fires is due to the cooling and isolation properties of the chemicals used. In order to stop thermal runaway, the battery must be contained and cooled as quickly as possible. To help aid the certified suppressant used in the VoltHub, the locker configuration helps to aid the isolation of thermal runaway by reducing the risk of the fire spreading.

The foam suppressant in the VoltHub contains a special formula, which is designed to neutralise the chemical reaction in a failed Li-Ion battery. This makes it almost impossible for the fire to reignite and the aftermath can be safely dealt with.



## Fire Safety

The VoltHub Fire System is suitable for type A, B, D, and F fires, as well as Lithium fires.

The VoltHub Fire System is a pressurised analogue system. The VoltHub is designed to automatically detect the source of the fire in its respective locker.

The VoltHub Fire System is a reactive system that works independently and requires no power.

Maintenance free, the VoltHub Fire System only requires regular annual checks in line with standard fire extinguisher regulations.

