

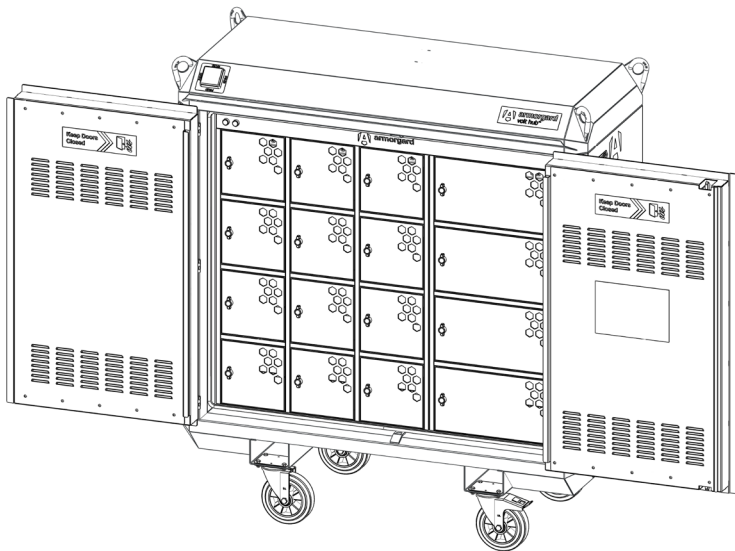

# volthub™

## Operational and maintenance manual

Suitable for: VH16-110, VH16-240





# Welcome

Welcome to your Armorgard VoltHub. An all-in-one, indoor and outdoor use, IP rated Li-ion safe battery charging unit that constantly and pro-actively keeps fire risks at bay, and dramatically reduces the hazards created by thermal runaway.

**Please read this operational and maintenance manual carefully prior to using the VoltHub.**

**Please note that the unit should only be used as supplied and detailed in this manual. No adjustments, alterations, or changes should be made to the unit without prior written consent from Armorgard.**

**Armorgard accepts no liability for unauthorised modifications made to the unit which may damage or cause compromised operation of the unit and will breach our terms of use and warranty policies.**

---

# Contents

Safety information.....	4
Fire plan.....	7
Electrical safety information.....	8
Safe working conditions for battery charging.....	9
In the event of a fire.....	10
Instruction for the fire department.....	10
After a fire.....	11
Fire system maintenance.....	12
GSM set-up.....	12
What's included.....	13
Product specification.....	13
You'll need.....	14
Getting to know your VoltHub.....	15
How to assemble.....	16
Fitting the castors.....	17
How to use.....	18
Connecting VoltHub to a wireless site fire alarm system.....	21
Setting up VoltHub for indoor use.....	23
Using the temperature alert system.....	25
Lifting the VoltHub.....	27
Storing the unit.....	28
Transporting the unit.....	29
Equipment care.....	30
Ongoing maintenance.....	30
DLP Fire System Maintenance Record.....	31
Warranty.....	32
Spare parts.....	32



## Safety information

- » Before using the VoltHub, ensure any relevant risk assessments are carried out, especially fire safety. The VoltHub is a safe and secure method for charging and storage of tool batteries - Armorgard cannot be responsible for accidents that occur due to negligence or misuse, nor any accidents/damage as a result of misuse to either personnel or property.
- » Connect the unit to power supply for 48 hours to ensure battery is fully charged.
- » The unit must NOT be tampered with - this will void warranty and increase risk of danger.
- » As part of fire risk assessment, inform your local fire department of the use of VoltHub when on location.
- » Ensure the VoltHub is not damaged before using it.
- » Always KEEP DOORS SHUT and lock the VoltHub when not in use or out of sight.
- » All personnel using the VoltHub should be familiar with safe operating procedures.
- » Do not tamper with, or alter the fire suppression system installed at any time.
- » Do not charge batteries larger than 350Wh per locker (subject to being OEM, undamaged and inspected regularly).
- » Only move the VoltHub when empty, and doors closed.
- » Always charge batteries INSIDE the red locker compartments.
- » Ensure the VoltHub is thoroughly examined before lifting via crane or moving it. Only qualified personnel should lift the VoltHub. Carry out a risk assessment before lifting or lowering the VoltHub to ensure there is not risk of injury. Ensure a valid LOLER certificate is in place.
- » Before charging or placing a battery inside the VoltHub, ensure it meets the safety criteria found on the inside door sticker and detailed in this manual.
- » Always use OEM certified charging equipment.
- » Do not run extension leads from the locker sockets.

- 
- » If the emergency light on the roof of the VoltHub is flashing and the siren is sounding, DO NOT ENTER OR OPEN THE UNIT UNDER ANY CIRCUMSTANCES. Alert the fire service immediately and always follow their instructions.
  - » Always use the fork pocket access points when moving by forklift.
  - » Position the VoltHub away from hot works, DSEAR and COSHH areas, naked flames, smoking areas, and high dust areas.
  - » Position the VoltHub 1 metre minimum distance from surrounding walls.
  - » The extension lead must be connected to a grounded (earthed) power supply.
  - » Where possible, the VoltHub should be left plugged in with the power on, to ensure the emergency battery backup inside the unit is fully charged.
  - » When the VoltHub is not in use, turn the Isolator switch to “off” position.
  - » When using the VoltHub outdoors, keep out of direct sunlight to increase battery charging safety.
  - » When using outdoors, keep at least 1 metre of open space behind the VoltHub to allow for suitable effluent gas dispersion.
  - » Only use the VoltHub within its operating temperature range of -10°C to +45°C.
  - » When using the VoltHub inside, ensure the ventilation exhaust at the rear of the unit is ducted outside of the building.
  - » Never block the rear ventilation of the VoltHub. The doors should be free from obstruction to pass air flow and the rear exhaust should also be free to flow air.
  - » Do not cover or obstruct the red ‘FIRE’ light on the roof of the VoltHub.
  - » Always lock the castors when the VoltHub is in a static location.
  - » Castors should be checked regularly to ensure they are fit for purpose.



- » Each locker has a UDL 40kg load rating. This must not be exceeded.
- » Always position the unit on flat, stable ground with castors locked.
- » Keep the VoltHub clean and free from dust and debris.
- » You must always follow the VoltHub service and maintenance criteria.
- » The equipment is not to be used by people (including children) with reduced physical, sensory or mental capabilities, or lack of experience and knowledge, unless they have been given supervision or instruction. Children must not play with the equipment.
- » If the supply cord is damaged, it must be replaced by the manufacturer, its service agent or similarly qualified persons in order to avoid a hazard.
- » Locker compartment sockets are for battery chargers only. Under NO circumstance should the VoltHub be used as an extension lead for powering electronic tools.
- » Any charging leads must be pushed to the back of the locker compartments before closing the doors.
- » Chargers must be left inside the locker compartments. No trailing lead connected to a socket within the VoltHub should leave the door threshold of a locker compartment.
- » Power leads for chargers must be inspected for damage every time the door to a locker compartment is opened. If damaged or considered potentially damaged it must not be used.

### **Conformity Statement**

**The equipment fulfils the requirements of 2014/35/EU - the Low Voltage Directive, and the associated safety standard EN 60335-1: 2012 and EN 60335-2-29: 2019. This statement also applies to the UK Electrical (safety) Regulations - 2008**

---

# Fire plan

## **As part of your routine fire inspection, you must:**

- » Ensure that the fire department knows how the VoltHub will be used and how the unit works. They should be made aware of the location of the unit.
- » For larger facilities with emergency response plans, you must log with the fire department on local information as a point of interest
- » This will ensure clarity in the event of a fire, where the responders understand the fire prevention capabilities of the VoltHub.



# Electrical safety information

- » Do not subject the total power draw inside the VoltHub beyond 32A at any time.
- » The power supply must have sufficient over-current and surge protection.
- » Ensure an assessment has been made of any electrical hazards before using it.
- » Ensure that all persons using the VoltHub understand it's limitations and safety requirements for risk free operation.
- » Ensure trailing cables do not pose a trip hazard.
- » Check that socket outlets are not overloaded by using unfused adaptors. For 240V units, regularly test the RCD function on each socket. For 110V units, ensure the transformer being used on site is RCD protected.
- » Switch off and unplug appliances before cleaning or adjusting them.
- » All equipment being charged should have an up-to-date PAT test completed.
- » Stop using equipment immediately if it appears to be faulty or damaged.
- » Turn off all appliances when not in use.
- » A qualified person should determine the relevant earthing requirements.
- » Do not handle electronic equipment in wet conditions.

---

## Do

- ✓ Follow guidance of all stickers on VoltHub
- ✓ Follow guidance of battery manufacturer
- ✓ Set up the VoltHub with a remote alert system
- ✓ Situate VoltHub away from exit routes

## Don't

- ✗ Leave doors open under any circumstances
  - ✗ Leave castors unlocked when stationary
  - ✗ Exceed locker potential energy fire rating
  - ✗ Store batteries fully charged
-

---

# Safe working conditions for battery charging

**All batteries placed on charge within the VoltHub MUST first meet the following checks:**

- » Check the case of the battery does not have any physical damage, swelling or leaks.
- » Ensure no corrosion of charging terminals.
- » Ensure the battery is dry.
- » Check for error lights or warnings on the battery and/or charger. Only use approved/certified OEM chargers and batteries.
- » Check the charging cables for any damage.
- » Never store combustible material inside the lockers.
- » Do not charge batteries larger than 350Wh per locker (subject to being OEM, undamaged and inspected regularly).
- » Do not overload the individual locker compartments.
- » Always follow the battery manufacturer's safety information/advice.
- » Remove battery when fully charged.
- » Do not use multi-socket extension leads inside the unit.
- » Always shut locker doors after placing batteries inside the lockers.
- » Do not stack batteries on top of each other.
- » Space chargers at least 5cm away from each other.

**The fitted fire extinguisher must be serviced and maintained in accordance with the recommendations and frequencies of BS 5306-3:2017, BS 5306-9:2015 and all future amendments. The fitted DLP fire suppression system must be serviced with relevant standards such as LPCB LPS1666.**



## In the event of a fire...

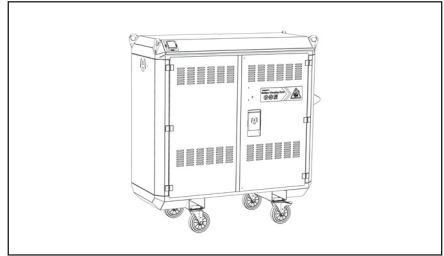
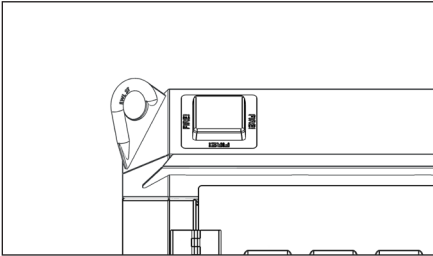

**1.** If not connected to a pre-existing fire alarm system and LED “FIRE” beacon is flashing and fire siren can be heard, dial 999.

**2.** Do not approach the unit - power is automatically isolated. We recommend disconnecting the lead from power source if possible. If indoors, ensure unit is exhausting away from a confined area. If tied to an existing service plan, Armorgard must be contacted for re-commissioning.

## Instruction for the fire department

1. 6Ltr DLP Fire Suppression System fitted.
2. Fan is powered on when a fire is detected (12v battery backup).
3. Unplug the unit from the power source if possible.
4. Give the unit time to exhaust gases and cool down.
5. Contact Armorgard

---

## After a fire...

1. In the event of a fire, once the threat of fire has been completely neutralised, fire department contacted and unit is verified as safe by someone with correct authority, the unit is to be left and not interfered with in any way.
2. The suppressant will be contained in the VoltHub's bunded sump.
3. If tied to an existing service plan, Armorgard must be contacted for re-commissioning. Armorgard will then dispose affected locker of batteries and chargers. If the owner is removing contaminated waste, it must be done in accordance with appropriate waste disposal requirements:

The EC Directive on WEEE aims to minimise the impact of electrical and electronic goods on the environment, by increasing re-use and recycling and reducing the amount of WEEE going into landfill. In essence, some of the chemicals and metals in electrical items can be harmful to the soil and human health when disposed of in landfill sites. By working together, we can all reduce the amount of landfill and resulting contamination.

The customer is responsible for disposing of the WEEE at the end of its life unless otherwise agreed.

Please dispose of electrical and electronic equipment through a Designated Collection Facility (DCF) where special facilities exist for correct disposal.

4. Armorgard will determine with the unit owner, during a site visit, whether a recommission of the unit is possible or if the unit is to be written off.



## Fire system maintenance:

- » Ensure the VoltHub is kept in a serviceable condition in accordance with the supporting maintenance documentation - scan the QR code for more information:



## GSM set-up:

(If purchased as an optional extra)

- » Unit is supplied ready to plug in and use. No adjustments, alterations, or changes should be made to the unit without prior discussion with Armorgard. The exception to this is programming the GSM notification system - scan the QR code for instructions:



**This operational and maintenance manual MUST be kept in the premises information box.**

**Whilst every effort has been made to ensure this operational and maintenance manual covers every aspect needed to operate your product safely, please take care whilst using the product and always operate with caution. Always liaise with management personnel on site for any additional operational restrictions that you need to be aware of. Risk assessments should always be carried out when using any equipment.**

# What's included...



1x VoltHub unit

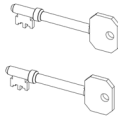

2x keys

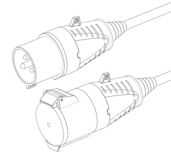

1x IP67 extension lead

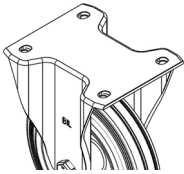

1x Castor kit

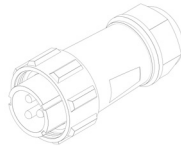

1x SP21 male connector

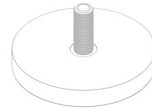

4x magnetic studs

# Product specification

Product Code	Description	Weight (kg)	External Dimensions W x D x H (mm)	Internal Dimensions W x D x H (mm)
VH16-110	110V VoltHub	334	1770x750x1820	Small locker: 260x355x260
				Large locker: 475x355x260
VH16-240	240V VoltHub	334	1770x750x1820	Small locker: 260x355x260
				Large locker: 475x355x260



## You'll need...

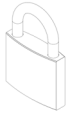

16x padlocks  
less than 20mm  
in depth

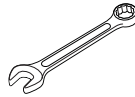

13mm span-  
ner ratchet or  
socket (if adding  
castors)



1x contract SIM card  
or pre-existing wire-  
less fire alarm system  
(for alert functionality)  
If you have purchased  
the GSM as an op-  
tional extra



1x PZ2  
screwdriver  
(to set up for  
indoor use)



1x intumescent  
sealant  
(to set up for  
indoor use)



1x 150mm diameter  
ducting and duct clamp  
(to set up for indoor  
use)



1x 150mm/6inch  
diameter ducting  
flange  
(to set up for  
indoor use)

# Getting to know your VoltHub™

A world first solution to charging Li-ion batteries safely

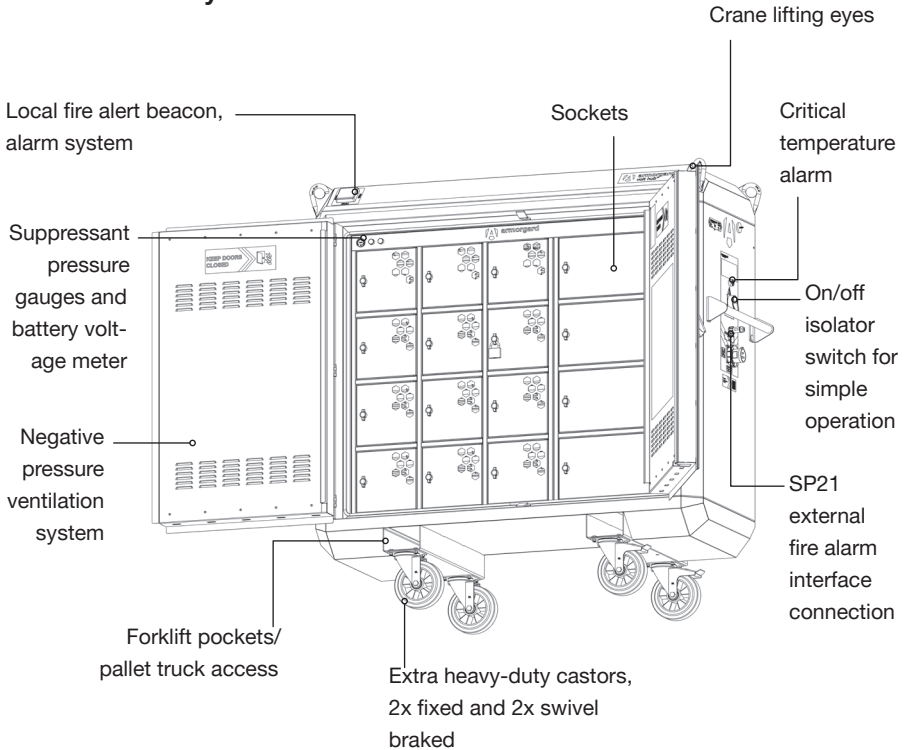

Power supply  
110V (VH16-110)  
240V (VH16-240)



Automatic fire  
suppression



Ventilation



Audio and  
visual alerts



Power inlet  
110V 32A IP67 (VH16-110)  
240V 32A IP67 (VH16-240)



## How to assemble

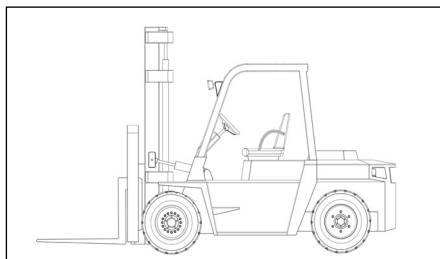

- 1.** You will require a forklift or pallet truck when unloading your VoltHub. You may also need to add castors to the unit.

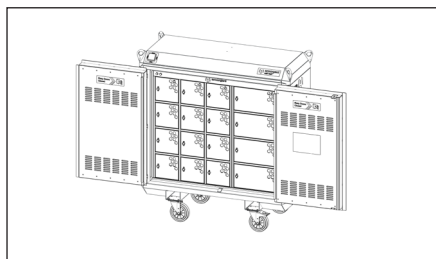

- 2.** It is important to check that product is not damaged upon arrival and all parts are intact, particularly assessing electrical components. Make a note of the unique serial number located on the right hand side of the unit.

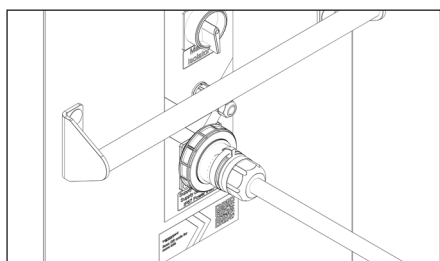

- 3.** The unit **MUST** be plugged into mains power to **FULLY** re-charge the internal battery backup, after delivery and before use.

---

## Fitting the castors

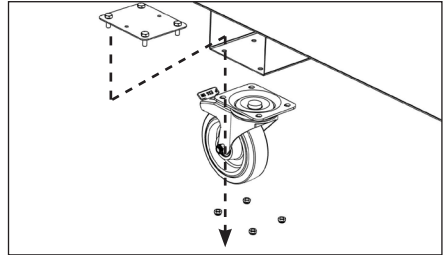
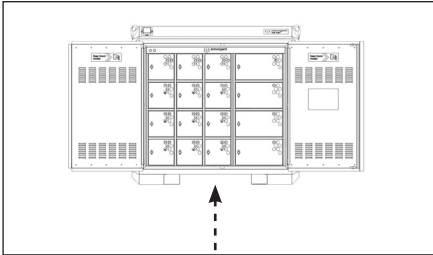

**1.** You may need to fit castors to the VoltHub. Firstly, lift the unit onto a stable platform - do NOT lie on its back. The unit MUST be empty when fixing castors.

**2.** Insert castor plates into the forklift skids. Put the castor wheel in place and use a 13mm socket to tighten the M8 nylocks.

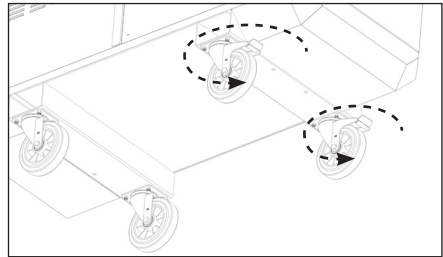
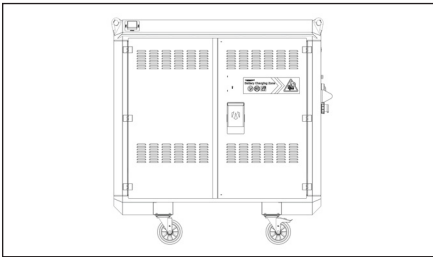

**3.** Armorgard castors kits come with 2x fixed and 2x swivel-braked castors. Fix the 2x fixed castors on the left and 2x swivel-braked on the right, the same side as the handle.

**4.** Repeat step two for the other wheels. Once complete, check all nuts are tight, and then ensure the two braked castors can swivel through 360° before lowering the VoltHub.



## How to use

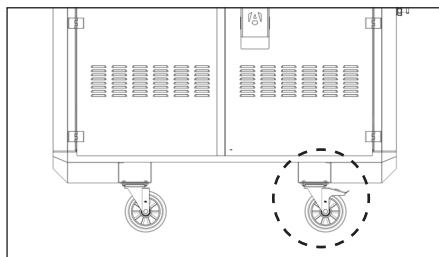

- 1.** Once you have placed the VoltHub on a stable, even surface, lock both the castors.

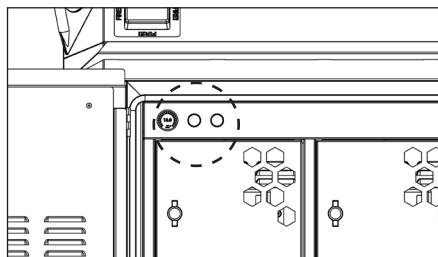

- 2.** Open doors before plugging in. Follow all routine inspections as outlined on page 31 of this manual.

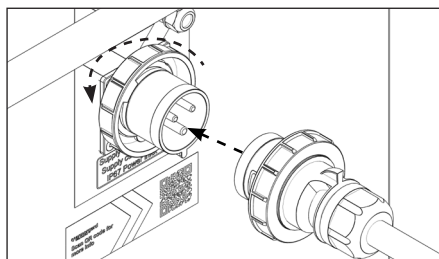

- 3.** Using the supplied extension lead, connect unit to a power supply. Insert the lead and twist the locking collar anti-clockwise to secure the extension lead. Ensure the lead is attached securely and will not cause a trip hazard.

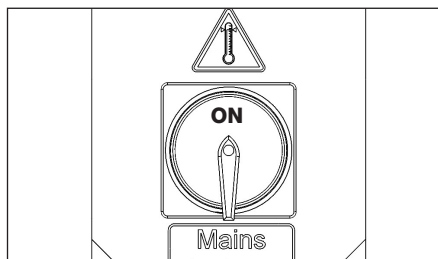

- 4.** Turn the isolator switch to the 'On' position to power the sockets for charging. There will be 2 audible beeps and flashes from the critical temp alarm to confirm the unit has been turned on with power.

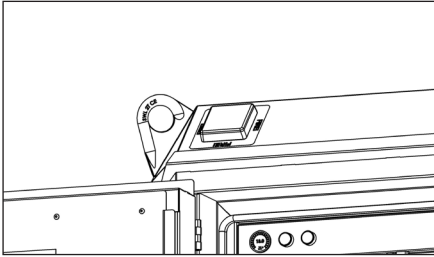

- 5.** Additionally, the red LED fire beacon will also remain lit for 5 seconds to show the emergency systems are working. If the unit does not confirm power or functioning emergency systems in this way, first leave the unit on charge to allow the internal battery back up to charge. In the unlikely event that, after 48 hours of charging, the unit does still not confirm power or functioning emergency systems, please contact Armorgard.

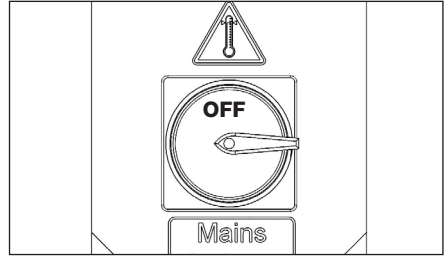

- 6.** Turn the isolator switch to the 'off' position to turn power off to the sockets.

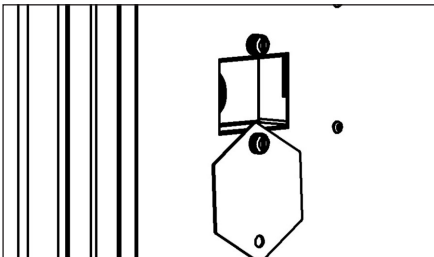

- 7.** If you have purchased the optional extra GSM and you require call and text notification, follow the GSM set up instructions for how to do this. Scan the QR code for instructions.



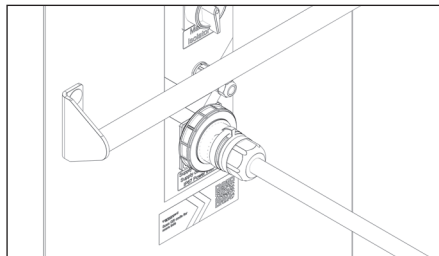

- 8.** All the safety control systems within the VoltHub will continuously monitor and maintain the optimum charging and fire safety parameters within the unit, regardless of the VoltHub being powered on or off. However, it is recommended that VoltHub is left plugged into the power supply to maintain charge in the 12v battery backup.

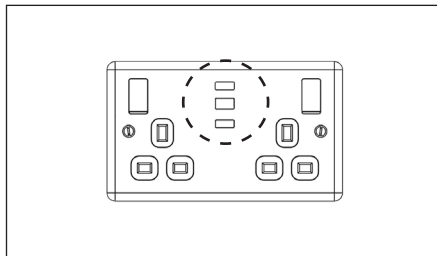

- 9.** For 240V units only: The sockets in the VoltHub are individually RCD protected. There are 2 buttons located on the face of the socket, a test button (red) and a reset button (orange). The indicator at the top of the socket will show red-on or green-off. Always press the test button before each use. Should an appliance trip the socket, remove the plug and press the reset button to continue use.

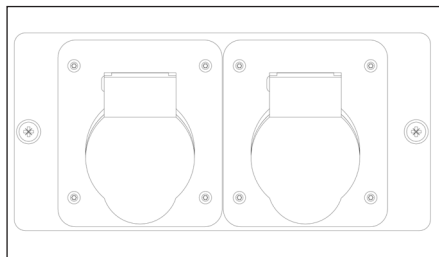

- 10.** For 110V units only: Ensure the transformer used on site is RCD protected. Ensure any appliance plug caps have been successfully un-clipped prior to attempting to remove the plugs from the socket. This is to prevent damage to the sockets and fascia plates.

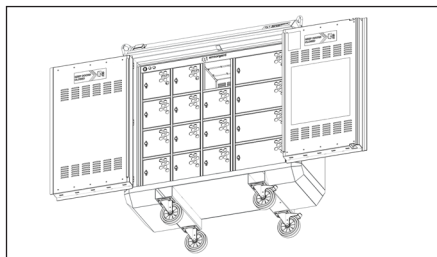

- 11.** In the top centre locker, there is an access hatch. This is to be used for annual maintenance and should ONLY be opened by a trained, competent engineer. The hatch should otherwise remain closed and covered.

---

# Connecting VoltHub to a wireless site fire alarm system

The VoltHub is compatible with most pre-existing fire alarm systems. Please contact Armorgard if you have any questions regarding compatibility.

It may also be necessary to contact your fire alarm system provider to prepare the interface.

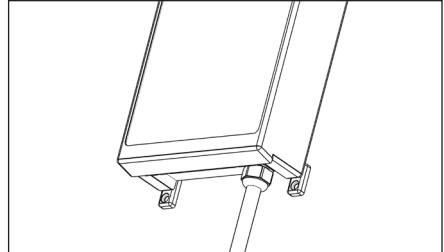
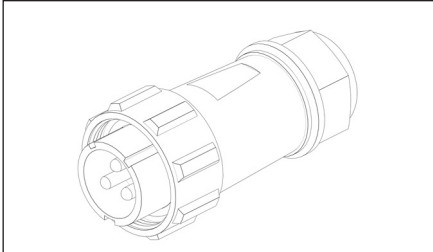

- 1.** Terminate a suitable length of 3 core flex into the SP21 plug provided. The terminals of the socket are wired to '1' as 'normally open', '2' as 'normally closed' and '3' as 'common'. It will be necessary to know whether the fire alarm system operates as a normally open or normally closed circuit. The contacts are volt free.
- 2.** Terminate the other end of the cable into the existing fire alarm system.

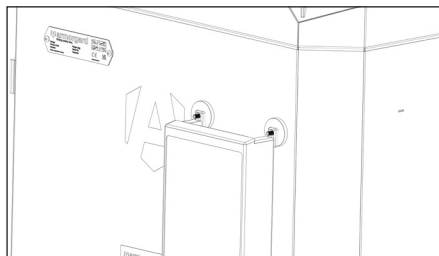

- 3.** The easiest way to locate a wireless interface onto the VoltHub is by using the rubber coated magnets provided.

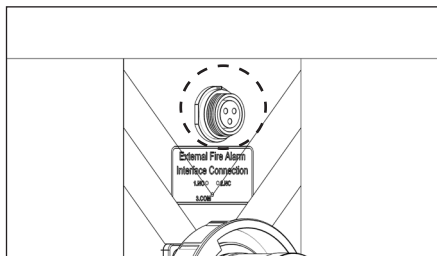

- 4.** Locate the 3 pin socket under the isolator switch and unscrew the IP rated cap.

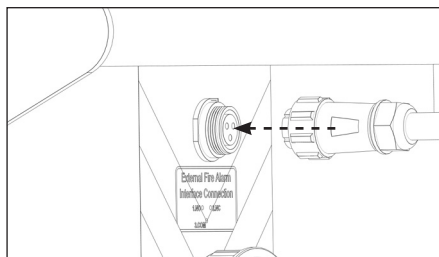

- 5.** Connect the alarm interface and tighten the locking ring. In the case of a false alarm, the system can be reset using the button located behind the cover panel in the top left locker compartment. In any other instances of an alarm, the standard emergency procedures should be followed.

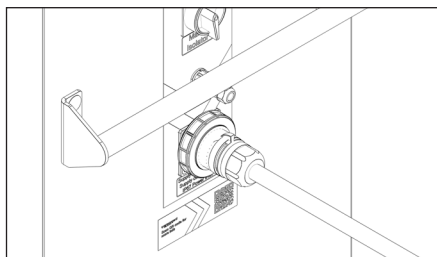

- 6.** All the safety control systems within the VoltHub will continuously monitor and maintain the optimum charging and fire safety parameters within the unit, regardless of the VoltHub being powered on or off. However, it is recommended that VoltHub is left plugged into the power supply to maintain charge in the 12v battery backup.

---

# Setting up VoltHub for indoor use

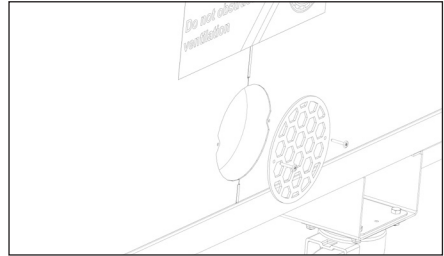
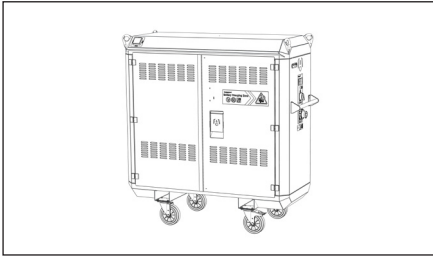

**1.** To safely use the VoltHub indoors, it is recommended to duct the ventilation outside to avoid a build up of fumes indoors, in the event of a fire.

**2.** Firstly, remove the ventilation panel at the rear of the VoltHub using a PZ2 screwdriver.

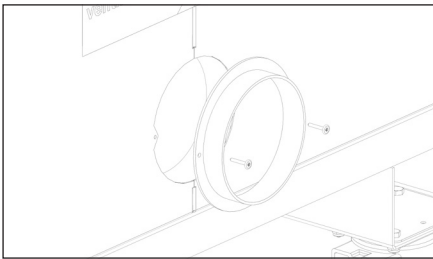

**3.** Replace the panel with a 150mm/6inch diameter ducting flange, using the same screws to attach the flange over the ventilation aperture. Depending on the fit of the ducting flange, it is recommended to seal the flange to the VoltHub body, using an intumescent sealant to reduce leakage.

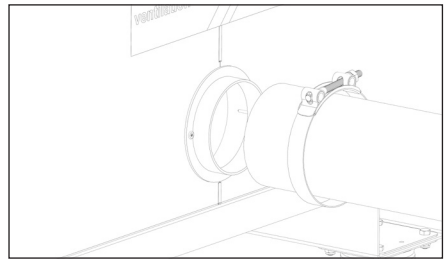

**4.** After affixing the new flange, connect a length of 150mm/6inch diameter ducting using a suitable duct clamp to secure it in place.

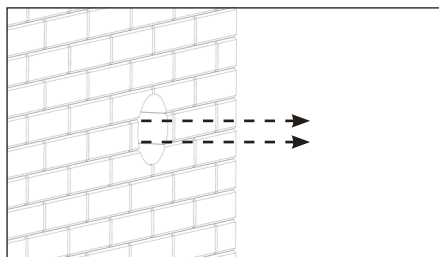

- 5.** Finish the installation by routing the opposing end of the ducting to outside of the indoor space, allowing exhausted gases to be ventilated to an outside atmosphere.

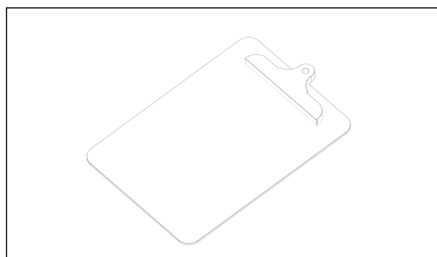

- 6.** Make a note of this exhaust location as part of the fire risk assessment.

---

# Using the temperature alert system

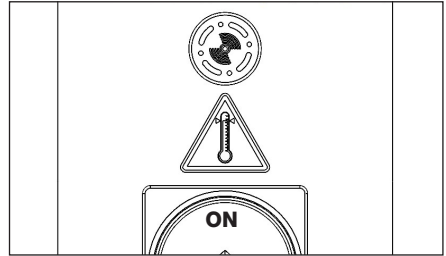
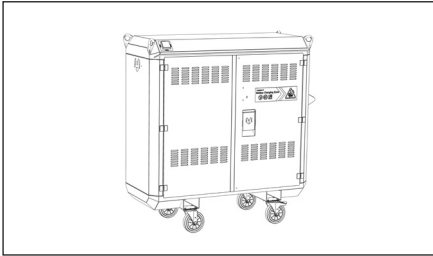

**1.** Should the internal temperature of the VoltHub exceed 60C, the power will automatically be isolated from the sockets and prevent charging.

**2.** The red LED light above the isolator switch will begin to flash and an audible beeping sound will be heard to alert the user the VoltHub is above the safe charging temperature.

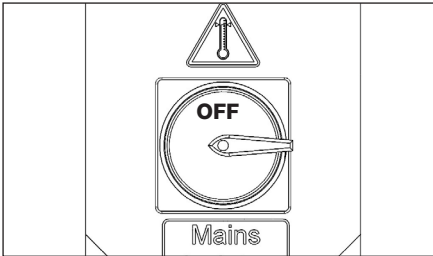

**3.** To silence the alarm, turn the isolator switch 'off' but keep the VoltHub plugged in. The unit must be given time to cool down before charging will resume.

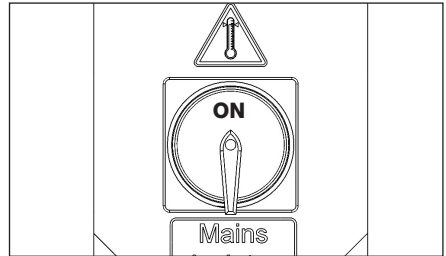

**4.** To check if the VoltHub has been returned to a safe charging environment, turn the isolator switch back 'on'. If the alarm is no longer sounding, power will be restored to the sockets and charging can resume.

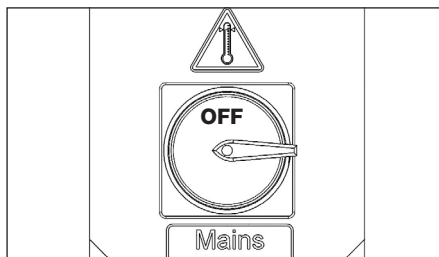

- 5.** If after turning the isolator switch back 'on' the alarm continues to sound, turn it 'off' to silence the alarm and allow more time for the VoltHub to return a safer charging environment. Periodically repeat this step until the alarm has deactivated.

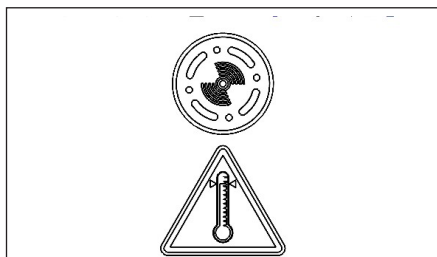

- 6.** If the critical temperature alarm is sounding however you cannot hear the fan running, you must contact Armorgard.

---

## Lifting the VoltHub

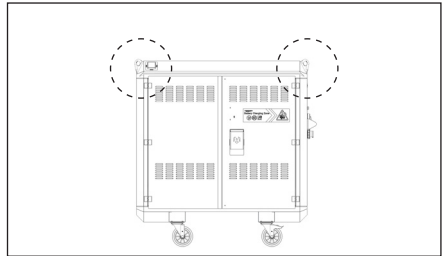
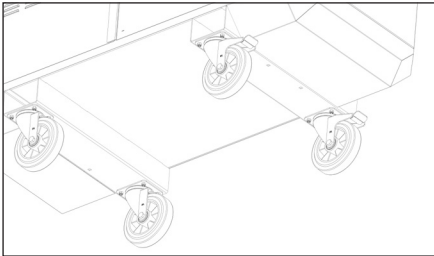

**1.** Prior to lifting, ensure the VoltHub has a valid LOLER certificate, both casters are braked, and the main doors are locked closed.

**2.** Attach a suitable 4 leg lifting chain or sling to each of the lifting points on the top of the VoltHub. All 4 lifting points **MUST** be used.

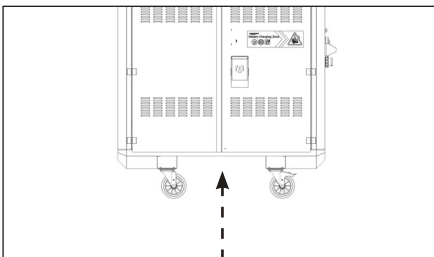

**3.** After checking no persons are in the immediate lifting area, carefully lift the VoltHub off the ground, checking the unit is balanced before moving to its final location.

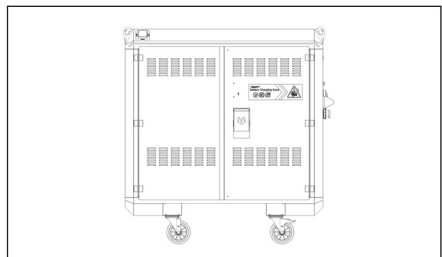

**4.** After carefully lowering the VoltHub to its final location, the lifting equipment can be removed. Perform all unit inspections as a new unit.



## Storing the unit

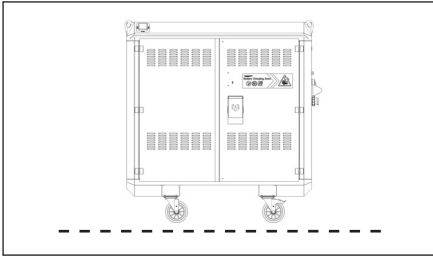

- 1.** When storing the unit, VoltHub should be positioned on level ground, in a cool, dry area.

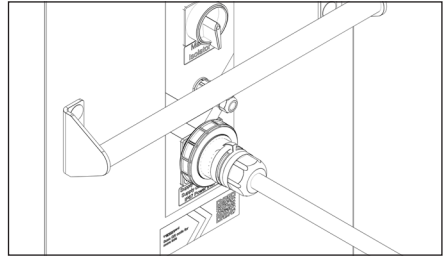

- 2.** Always keep the VoltHub plugged in to charge the internal battery backup. It is not necessary to switch the unit on for the internal battery backup charging to take place.

---

# Transporting the unit

The VoltHub has been designed specifically to make transporting the product easy.

The four crane lifting eyes come with the VoltHub and are attached to the roof. These are for ease of transporting the unit only. The unit should never be lifted when loaded.

Always use the forklift pockets when transporting by forklift.

When transporting the VoltHub, the doors must be locked.

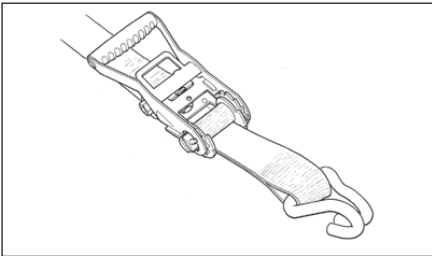

- 1.** During transport, ensure that the VoltHub is secured to the carrier by strapping down the unit fully.

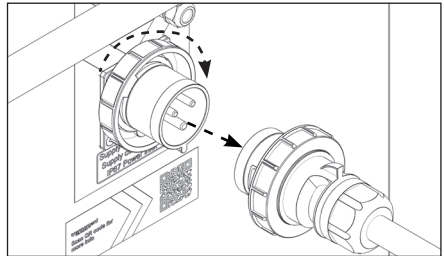

- 2.** When moving the unit, disconnect VoltHub from mains and be careful for trailing cables. Disconnect the lead by firstly twisting the locking collar clockwise from the inlet, then pulling directly out.



## Equipment care

The VoltHub is IP55 rated weather resistant and is suitable for both indoor and outdoor use. It is always important to note that electrics or equipment susceptible to water damage should be sealed and secured inside the lockers with the door kept closed.

When using outdoors, keep at least 1 metre of open space behind the VoltHub to allow for suitable effluent gas dispersion.

Always ensure that the product data plate remains visible and in good condition, especially the unique serial number, as this is required should you need a replacement lock or key. Always keep the doors closed at all times.

## Ongoing maintenance

It is important to check that the VoltHub is not damaged before every use.

We recommend for you to check the locks, forklift pockets, crane lifting eyes, plug sockets and rubber door seals every three months, to ensure that the VoltHub can operate fully. If the VoltHub will be under rigorous use, we recommend integrity checking regularly.

Always carry out integrity checks before lifting the VoltHub.

The VoltHub arrives fully tested. It is the customer's responsibility to carry out all relevant electrical testing on an annual basis.

A competent person should follow the weekly inspection checklist as outlined on page 31 of this manual. Any damage should be immediately reported, including loss of pressure.

Keep the ventilation clear. You may need to remove the vent to gently clear/clean the ducting behind it.

To ensure optimum and safe functionality of your VoltHub, it is critical to adhere to the following maintenance instructions. Scan the QR code for more information:



---

# DLP Fire System Maintenance Record

To ensure optimum functionality of the fire suppression system, it is recommended that the following visual inspection is carried out each week by a competent person:

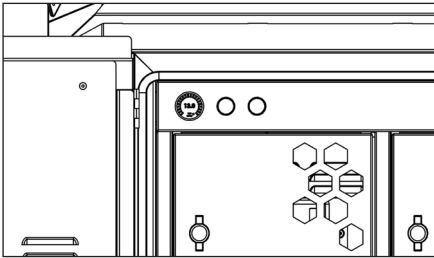

- 1.** Check both pressure gauges are reading in the green. Check battery voltmeter is reading at a minimum of 12.6V and the green is visible on the gauge.

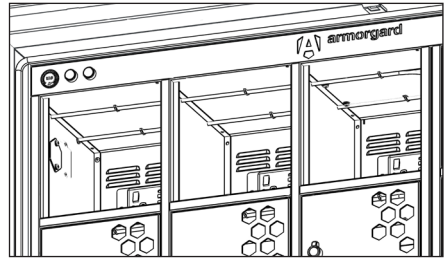

- 2.** Check the detection hose for damage. This includes deep gouges, cuts, creasing and folding of the hose. Ensure that the hose is secured within every clip of each compartment. Should the hose be free from a clip, that section of detached hose should be inspected, and provided there is no damage, should be pressed back into place.

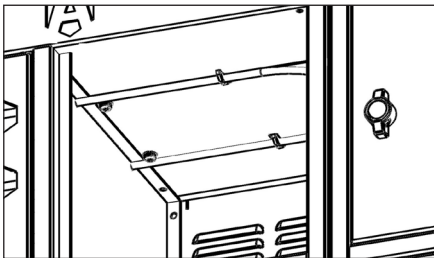

- 3.** Ensure the access hatch in the roof of the top central locker is closed and the cover plate is securely fixed in place. If the cover plate is missing or damaged, get in touch with Armorgard.

- 4.** Ensure the upper rear of the VoltHub body has not sustained excessive damage.
- 5.** Check the condition of rubber door seals and replace if damaged.
- 6.** Report any potential problems immediately to the owner.



## Warranty

Armorgard products are built to last, and all have a manufacturer's warranty of 12 months - please refer to the terms and conditions for what this covers.

We also keep replacement keys and offer replacement locks for all Armorgard products up to five years old. To get a replacement key, all you'll need is the distributor you purchased from, proof of purchase and your product's serial number, which can be found on the data plate of every product.

Do not force entry into the product, as this could affect the warranty. Always contact us if you require a replacement lock or key.

Please note that the unit should only be used as supplied and detailed in this manual. No adjustments, alterations, or changes should be made to the unit without prior written consent from Armorgard. Armorgard accepts no liability for unauthorised modifications made to the unit which may damage or cause compromised operation of the unit and will breach our terms of use and warranty policies.

## Spare parts



Replacement keys



Replacement castors



Replacement deadlocks

Other spare parts available. Please get in touch for more information.



For additional support and easy access to spare or replacement parts, register your product following the QR code:



---

# Notes



# Notes

---

# Notes



Find us on social media:



**UK Head Office**

Unit 14-16, Standard Way, Fareham Industrial Park, Fareham, Hampshire, PO16 8XB  
+44 (0) 23 9238 0280 | [sales@armorgard.co.uk](mailto:sales@armorgard.co.uk) | [www.armorgard.co.uk](http://www.armorgard.co.uk)

**France Office**

+ 33 (0) 4 81 16 06 69  
[commercial@armorgard.fr](mailto:commercial@armorgard.fr)  
[www.armorgard.fr](http://www.armorgard.fr)

**North America Office**

1-877-794-2848  
[info@armorgardusa.com](mailto:info@armorgardusa.com)  
[www.armorgardusa.com](http://www.armorgardusa.com)